

SPECIFICATION DATA

IPE-100X180



Product Details

- Protect electrical equipment from environmental factors like water, dust, and accidental contact.
- Secures system in place for a better and stable inspection.
- Comply with IP65 which offers complete protection against dust and protection against low-pressure water jets from any direction.
- Compatible on a moving robot arm.

Features & Benefits

- Made of aluminium with shining clear & gold color.
- Supplied with silicon o-ring & polycarbonate mirror.
- Supplied with certified IP54 split cable gland.
- Come with 4X M4 nuts for machine assembly.
- Compact with camera mounting.
- “PLUG AND PLAY” design.
- Customized unit available to fit special lighting, camera and lens.

Lighting Specifications

Mechanical	
Casing Material	Aluminium
Storage & Operating Temperature Range	Temp 0 - 45°C, Humidity 20-85%
Weight (g)	200
Dimension (mm)	70 X 32 X 20.5

Illumination	
Lighting	Ringlight
Colour	White
Emission Angle (deg.)	15
Eye Safety Class	II

Electrical	
Lighting Supply Voltage (V)	24V ± 2%
Continuous Current (mA)	370
Power Consumption (W)	4.44

Lighting Connection	
Connector Type	JST SMR-03V
Cable Length (mm)	500

Application	
Illumination Type	Direct Illumination
Application Use	Substrate inspection, label inspection, flat surface, fiducially recognition.

Ingress Protection(IP) Enclosure Specifications

Material	Aluminium
Color	Shining Silver & Gold
Protection Level	IP65
Length (mm)	205
Width (mm)	100
Height (mm)	100
Cable Holes	4
Compliance	CE, RoHS, REACH
Accessories	Cable Gland & Camera Mounting

IPE Dimension Layout

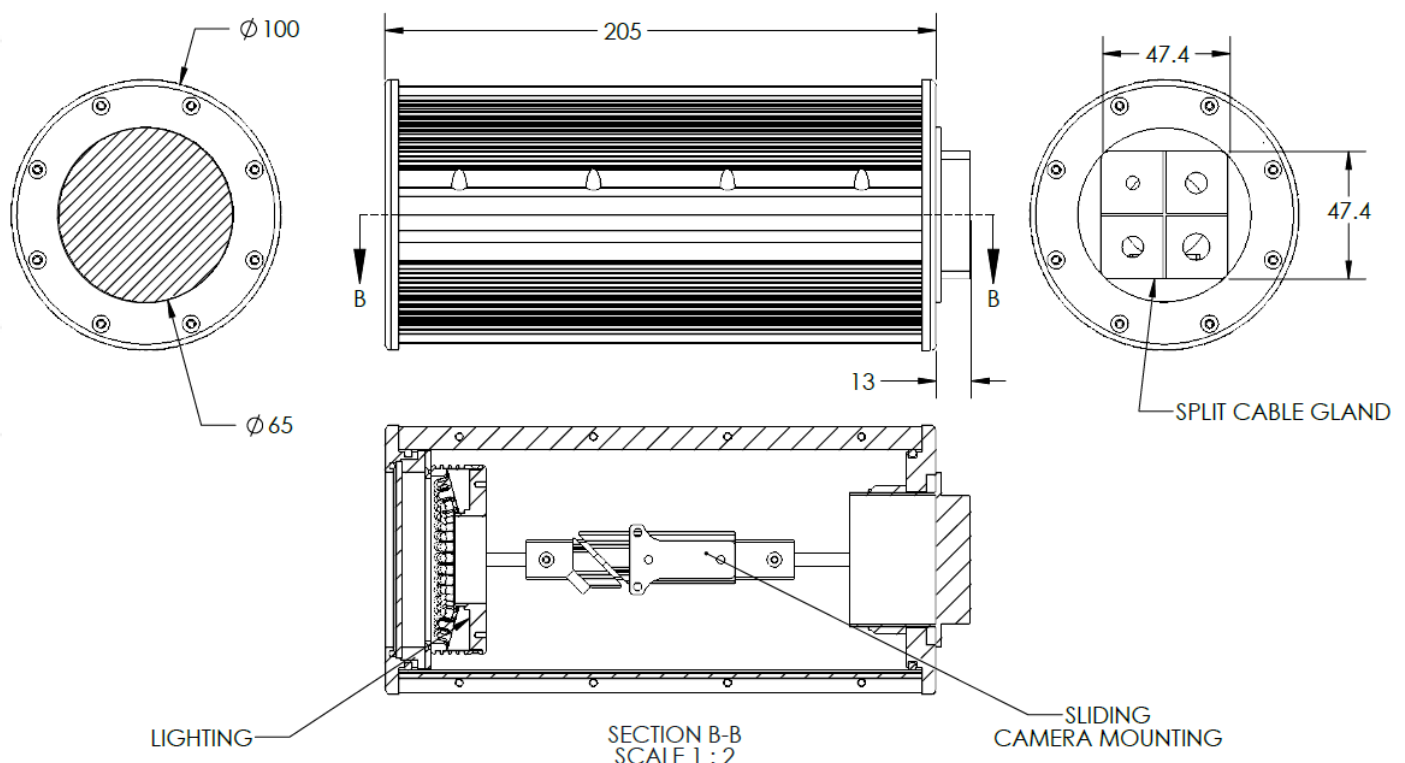

Lighting Connector Pin Configuration



PIN 1	RED	24V
PIN 2	N/A	N/A
PIN 3	WHITE/BLACK	GND

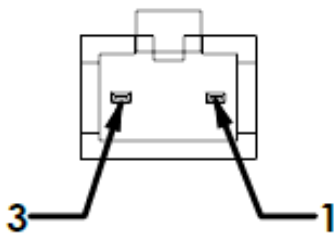

Packing list



No.	Items	Quantity
1.	IPE-100X180	1
2.	LIGHTING	1
3.	M4 NUT	4