

SPECIFICATION DATA

IPE-130X200



Product Details

- Protect electrical equipment from environmental factors like water, dust, and accidental contact.
- Secures system in place for a better and stable inspection.
- Comply with IP68 which offers complete protection against dust and protection against high-pressure water jets from any direction.
- Compatible on a moving robot arm.

Features & Benefits

- Made of Stainless Steel 304 grade.
- Supplied with silicon o-ring & polycarbonate mirror.
- Supplied with certified IP68 split cable gland
- Come with 3X M5 nuts for machine assembly.
- Compact with camera mounting.
- “PLUG AND PLAY” design.
- Customized unit available to fit special lighting, camera and lens.
- Come with M12-to-ferrule extension cable and M8-to-M12 cable adapter.

Lighting Specifications

Mechanical	
Casing Material	Aluminium
Storage & Operating Temperature Range	Temp 0 - 45°C, Humidity 20-85%
Weight(g)	300
Dimension(mm)	105.2 X 105.2 X 29

Illumination	
Lighting	Ringlight
Colour	White
Emission Angle(deg.)	00
Eye Safety Class	II

Electrical	
Lighting Supply Voltage(V)	24V ± 2%
Continuous Current(mA)	480
Power Consumption(W)	11.52

Lighting Connection	
Connector Type	5 PIN M12 MALE
Cable Length(mm)	700

Extension Cable	
Connector Type	5 PIN M12 FEMALE
Cable Length(mm)	3000

Application	
Illumination Type	Direct Illumination
Application Use	Substrate inspection, label inspection, flat surface, fiducially recognition.

Ingress Protection(IP) Enclosure Specifications

Material	Stainless Steel 304
Color	Shining metal
Protection Level	IP68
Length(mm)	226
Width(mm)	125
Height(mm)	125
Cable Holes	4
Compliance	CE, RoHS, REACH
Accessories	Cable Gland, Camera Mounting, Cable Adapter, Extension Cable

IPE Dimension Layout

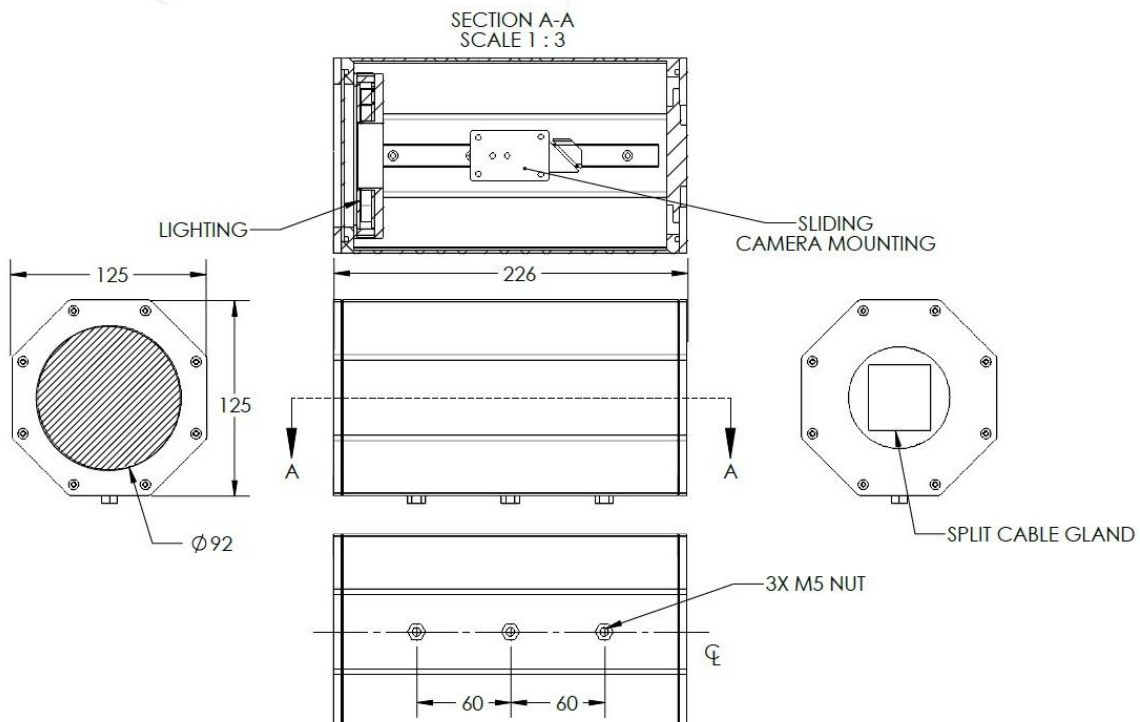

Lighting Connector Pin Configuration

MALE

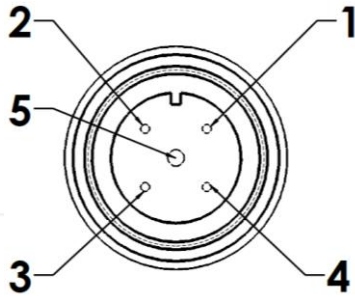

PIN 1	BROWN	24V
PIN 2	WHITE	-
PIN 3	BLUE	GND
PIN 4	BLACK	-
PIN 5	GREY	-

FEMALE

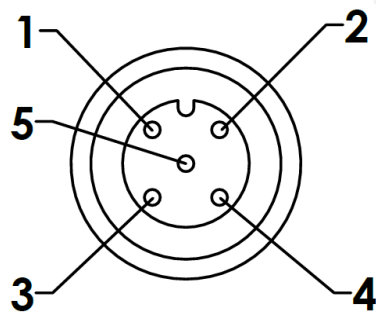

PIN 1	BROWN	24V
PIN 2	WHITE	-
PIN 3	BLUE	GND
PIN 4	BLACK	-
PIN 5	GREY	-

Packing list



No.	Items	Quantity
1.	IPE-130X200	1
2.	LIGHTING	1
3.	CABLE ADAPTER (M8-to-M12)	1
4.	EXTENSION CABLE (M12-to-ferrule)	1